

Operator's Manual

COMPACT UTILITY LOADER/SKID STEER BRUSH CUTTERS

Open Front/Compact Series

4201

4801 LF | 4801 SF

WHY READ THIS MANUAL?

Before operating your new Brush Wolf brush cutter, read this entire manual to understand **1) safety precautions, 2) operating instructions, and 3) maintenance schedule** to help keep you safe and your equipment running smoothly for years to come.



TAKE A MINUTE TO WRITE DOWN THE FOLLOWING INFORMATION
FOR FUTURE SERVICE, REPAIR, AND WARRANTY INQUIRIES.

OWNER REFERENCE INFORMATION

DATE OF PURCHASE _____

MODEL NO. _____

SERIAL NO. _____

DEALER NAME _____

SALES REP NAME _____

DEALER PHONE NO. _____

DEALER EMAIL _____

DEALER ADDRESS _____

THANK YOU

Welcome to the Brush Wolf family!

You've made a smart choice! We hope you love your brush cutter as much as we love making it. If you have any issues, please contact us at any time. We're here to help.

Brush Wolf

218-692-1050

info@brushwolf.com

www.brushwolf.com

WHAT'S INSIDE

SAFETY FIRST!	2-3
OPERATING YOUR BRUSH CUTTER	4-7
MAINTENANCE	8-10
TROUBLESHOOTING	11
HOW TO REPLACE BLADES	12
PARTS SECTION	
4201.....	14-15
4801 LF 4801 SF.....	16-17
WARRANTY INFORMATION	18

SAFETY FIRST!

FOR YOUR SAFETY, READ THESE INSTRUCTIONS.

The following safety instructions are provided to alert you to precautions that, if not followed, may cause serious injury to yourself or to others. Please read these instructions completely. Brush Wolf/Cross-Tech Manufacturing cannot cover every incident that might be a hazard. Extreme caution should be used at all times. Only use your Brush Wolf brush cutter for the purpose for which it has been designed.

SITE INSPECTION

Before operating your brush cutter, carefully inspect the area to be cleared. Remove any items that may be picked up and thrown by the cutting blades, such as wire, pipes, rocks, etc. Mark objects that are too large to move. This is an important step to avoid personal injury, damage to property, the brush cutter, or your compact utility loader/skid steer. If an object is struck while operating the brush cutter, immediately shut down power to both the brush cutter and the compact utility loader/skid steer. Any damage should be corrected and tested before the continuation of cutting.

COMPACT UTILITY LOADER/SKID STEER AUXILIARY HYDRAULIC FLOW

Check the specifications of your brush cutter's rated gallons per minute (GPM) to correctly match the hydraulic flow of your compact utility loader/skid steer to ensure proper operation.

EQUIPMENT INSPECTION

Disconnect the unit from the compact utility loader/skid steer. To inspect or to make repairs under the cutter deck, always block the unit securely to prevent accidental release of the lift mechanism.

Inspect all hydraulic connections to ensure they are tight, and hoses and shields are in good condition before applying pressure. Hydraulic fluid can escape under pressure and may cause serious injury or death. If this type of injury occurs, seek medical attention immediately.

SAFETY GEAR

Wear safety goggles, hearing protection, and a hard hat. If using a skid steer, only operate the skid steer behind a shatterproof forestry-rated door and cab.

DO NOT operate near bystanders, vehicles, pets, livestock, or buildings. Objects may discharge while cutting with the brush cutter and has the potential to cause serious injury.

DO NOT operate the brush cutter until everyone on your work crew is alerted to the dangers of walking up to the brush cutter while in operation.

DO NOT operate the brush cutter in conditions with poor visibility.

DO NOT operate while intoxicated or if taking medications that may impair your senses or reactions.

DO NOT allow children to operate the brush cutter. Only individuals with compact utility loader/skid steer experience who are well acquainted with the rules of safe operation should be allowed to operate the brush cutter.

DO NOT operate a skid steer without a shatterproof forestry-rated door and cab.

DO NOT place hands, feet, or other objects under the deck while the brush cutter is in operation.

DO NOT raise the mower deck while blades are rotating. Operation with the mower raised will expose the cutting blades and may cause serious injury or death to yourself or others.

DO NOT allow anyone or any item on top of the mower deck while in operation.

DO NOT expose the underside of the blades towards the you or the cab while in operation.

DO NOT continue operation if an unexpected object is struck. IMMEDIATELY shut down power to both the brush cutter and the compact utility loader/skid steer. Disconnect the hydraulic couplers from the power source. Evaluate the damage, repair, and then test the unit before operation.

DO NOT leave the brush cutter unattended while in a raised position. Always make sure both the runners are placed firmly on the ground and shut down the compact utility loader/skid steer.

DO NOT attempt to straighten blades. Order replacement blades if blades are bent, cracked, or damaged.

OPERATING YOUR BRUSH CUTTER

▶ START HERE

Verify your compact utility loader/skid steer's hydraulic flow to ensure it is within the brush cutter's rating range. The brush cutter's gallons per minute (GPM) rating is located on the serial tag of the brush cutter.

FIGURE 1: SERIAL TAG

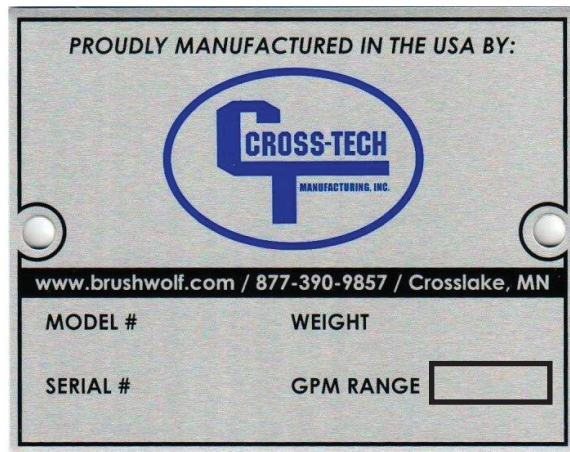

▶ IMPORTANT: CHECK THESE ITEMS PRIOR TO OPERATING

CHECK BLADES

Inspect blades to ensure they are sharp, tightened correctly, and intact. Look for damage, dullness, and cracks. See page 9 for details.

CHECK NUTS & BOLTS

Tighten the 1) blade carrier to the gearbox, 2) blade bolts/nuts, and 3) hydraulic motor mount nuts to torque specification listed on page 10.

CHECK HYDRAULIC FLUID

A low level could indicate a leak and require a closer inspection of your unit. See page 9 for details.

INSPECT THE DRIVE COMPONENTS

Remove any foreign material.

► CONNECTING THE BRUSH CUTTER

- 1) Connect the brush cutter to your compact utility loader or skid steer with the universal Quick Tach Mount Plate.
 - 2) Once connected, visually check the lock pins to make sure the brush cutter is securely locked into place. Raise the brush cutter to 12" above ground level. Loop the lift limit chain through the chain ring on your compact utility loader/skid steer and back to the chain bracket on your brush cutter.
- NOTE:** All Brush Wolf brush cutters come from the factory with the female flat faced coupler on the pressure line and the male coupler on the return line.

- 3) Inspect the hydraulic couplers and wipe off water, dust, or any debris which can damage hydraulic components. Once cleaned, connect the couplers from the cutter to the auxiliary hydraulic system on the compact utility loader or skid steer.
- 4) Make sure the hoses are routed in a way that allows the head to make a full range of motion. If hoses are too long and pinching or binding, they can be made shorter by loosening the hose bracket and feeding additional hose length back to the cutter deck.
- 5) Confirm all safety measures have been completed per the Safety First! section (pages 2-3). Most importantly, make sure the area is clear of people and pets.

FIGURE 2: HOSE ENDS

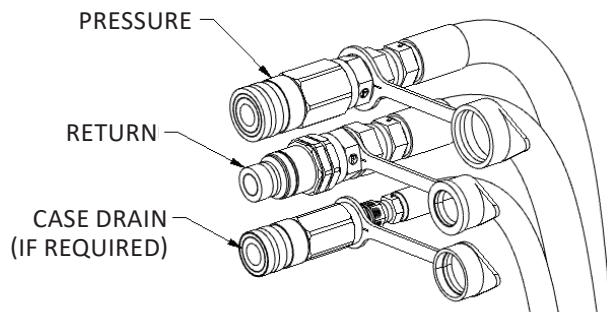

▶ OPERATING STEPS

- 1) Start the engine. The runners of the brush cutter should be as close to the ground as possible. **Never raise the brush cutter more than seven (7) inches off the ground while in operation.**
- 2) Slowly apply hydraulics to the brush cutter and increase the engine speed to high idle. Make sure the unit is operating smoothly before moving the compact utility loader/skid steer forward.
- 3) Check for proper blade rotation. **Blades should spin COUNTERCLOCKWISE as viewed from above** (see Figure 3). If rotation is reversed (clockwise), either inverse the flow from your machine or switch the QD couplers on the hose ends.

When temperatures are below zero, allow additional time for hydraulic fluid to warm up.

- 4) **Maintain compact utility loader/skid steer speed** appropriate for the volume of brush to prevent stalling.
- 5) Stay alert for drop-offs, rocks, holes, abandoned wells, and septic tanks. Do not operate or drive across a steep embankment as this may cause a rollover and possible injuries or death.
- 6) To **cut large diameter brush and trees**, move forward slowly to make the cut.

FIGURE 3: BLADE ROTATION

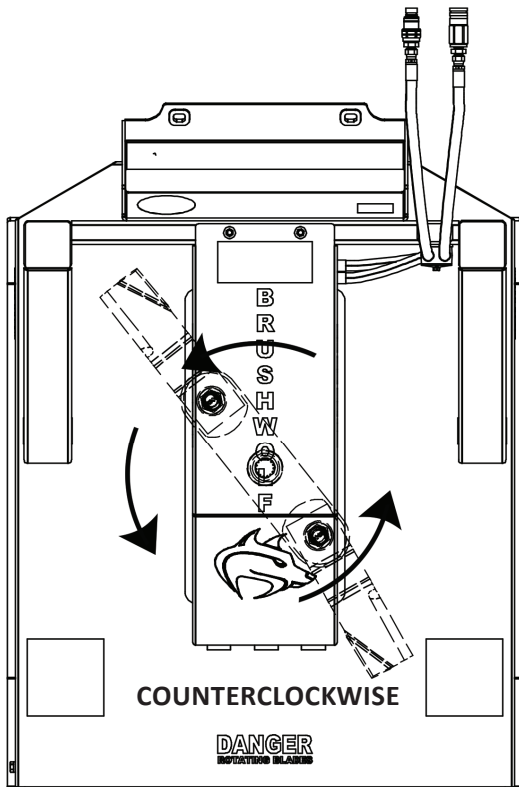

► WHEN DONE CUTTING

When done, lower lift arms, make sure the cutter is placed flat on the ground, throttle down on the compact utility loader/skid steer, and shut off the hydraulic flow to the brush cutter. Stop the engine and engage the parking brake. **Noise at shut down is normal.**

DISCONNECTING HOSES:

To disconnect hoses, use proper hand protection as the couplers may be hot. Always replace caps on hoses once removed to prevent contamination.

MAINTENANCE

BRUSH WOLF BRUSH CUTTERS ARE BUILT TO STRICT STANDARDS AND WILL DELIVER YEARS OF DEPENDABLE SERVICE WHEN YOU FOLLOW THESE MAINTENANCE GUIDELINES...

► MAINTENANCE SCHEDULE

See pages 9-10 for details.

ITEM	BEFORE EACH USE	DAILY OR EVERY 8 HOURS	AS NEEDED
Blades	Inspect		
Gearbox Lubricant	Check Oil		
Blade Bolt/Nuts		Torque to 775 ft-lbs	
Gearbox Castle Nut		Torque to 450 ft-lbs	
Gear Mounting Bolts		Torque to 275 ft-lbs	
Hydraulic Motor Mount Bolts		Torque to 75 ft-lbs	
Block (high flow units only)		Torque to 35 ft-lbs	
Shear Bolt Grade 2		Torque to 75 ft-lbs	
Hoses & Hose Safety Shield	Inspect		
Gearbox Shaft	Inspect		
Brush Cutter			Clean

CAUTION: Perform maintenance on a level surface with the unit firmly on the ground and blocked. Shut down the compact utility loader/skid steer and remove hydraulic hoses from the power source.

DO NOT loan your brush cutter to another compact utility loader/skid steer owner. The potential exists for hydraulic contamination and could shorten the life of your compact utility loader/skid steer or the hydraulic motor on your brush cutter. Contamination of the hydraulic motor voids the warranty.

► BEFORE EVERY OPERATION

❑ INSPECT BLADES

Inspect blades before each use to ensure they are sharp, tightened correctly, and intact. Look for damage, dullness, and cracks. Blades should rotate freely and be clear of obstructions. Replace the entire set of blades if damaged.

CAUTION: Always replace the entire set of blades. Never weld or straighten damaged blades, as loss of blade integrity may result.

❑ CHECK HYDRAULIC HOSES AND HOSE SAFETY SHIELD

Check for wear, damage, or leaks. Replace if damaged.

❑ INSPECT THE DRIVE COMPONENTS

Inspect before each use and remove foreign material.

❑ CHECK THE GEARBOX FOR PROPER LUBRICANT

To check the lubricant level, remove the pipe plug from the side of the gearbox. The lubricant should be the same level as the plug (see Figure 4). If low, add 85W-140 gear lube.

IMPORTANT: DO NOT overfill as too much lubricant may rupture the gearbox seals.

FIGURE 4: GEARBOX LUBRICATION DIAGRAM

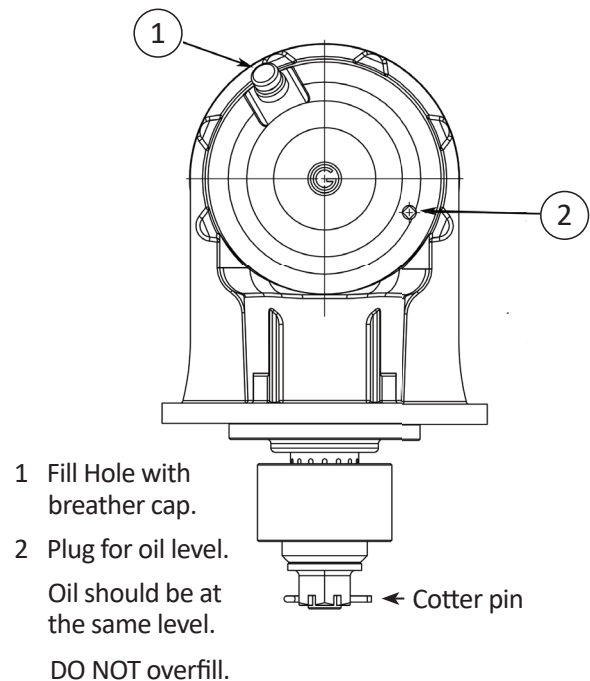

► BEFORE EVERY OPERATION

CHECK NUTS & BOLTS

Every Brush Wolf brush cutter is tested at the factory and all nuts and bolts have been tightened to specifications. We recommend you check the nuts and bolts after the first 4 to 6 hours of operation; then daily or every eight (8) hours.

Tighten the nuts that secure the blades to the blade carrier every eight (8) hours. Torque the nuts to 775 ft-lbs with a 1-11/16" socket wrench. The nuts are located under the access plate on the top of the blade carrier (see Figure 5).

FIGURE 5: ACCESS COVER

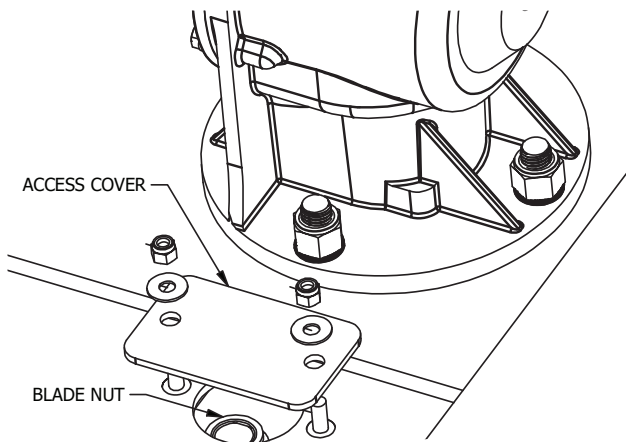

Also, tighten the castle nut holding the blade carrier to the output shaft of the gearbox. Torque to 450 ft-lbs with a 1-1/2" socket wrench. Insert cotter pin through hole on gearbox output shaft (see Figure 4).

Tighten gear mounting bolts daily or every eight (8) hours. Torque the bolts to 275 ft-lbs.

Tighten hydraulic motor mount bolts daily or every eight (8) hours. Torque the bolts to 75 ft-lbs.

Tighten block (high flow units only) daily or every eight (8) hours. Torque to 420 ft-lbs.

Tighten shear bolt grade 2 daily or every eight (8) hours. Torque to 75 ft-lbs.

Shear bolt protection (also known as butter bolt) at the motor coupler. It is recommended to carry additional shear bolts (1/2-13 x 3" GRD 2) obtained at most hardware stores. **Only use grade 2 when replacing.**

► AS NEEDED

- CLEAN THE BRUSH CUTTER** as needed and look for potential damage or obstruction that could result in poor performance.
- Make sure all **SAFETY DECALS** are visible.

TROUBLESHOOTING

CONSULT YOUR DEALER OR CONTACT BRUSH WOLF FOR ANY QUESTIONS OR ADDITIONAL HELP.

ISSUE	POTENTIAL CAUSES
Loss of Power	<ul style="list-style-type: none">• Low hydraulic fluid level• Overheated hydraulic fluid*• Contaminated hydraulic fluid*• Low gearbox lubricant level• Broken gearbox/motor shear pin• Missing input shaft key
Excessive Unit Vibration	<ul style="list-style-type: none">• Dull, broken, or damaged blades• Bent gearbox shaft• Blade carrier out of balance• Loose nuts and bolts• New blade or bolts matched with worn blade or bolts• Wire or rope wrapped around blades
Leaking Oil	<ul style="list-style-type: none">• Loose hydraulic connections• Ruptured hydraulic motor seals• Bent gearbox shaft• Loose or missing motor drain plug

*May damage hydraulic motor and void warranty.

HOW TO REPLACE BLADES

Perform replacement on a level surface with the brush cutter blocked off the ground. Shut off the hydraulic power supply and disconnect hydraulic couplers.

- 1) Take off the access cover (see Figure 5 on page 10) by removing the nuts and washers.
- 2) Through the exposed access hole, rotate the blade carrier to line up the nut of the blade for access.
- 3) Insert a 1-11/16" socket through the access hole and remove the nut and drop the bolts. **Caution:** once nuts are removed, blades will fall to the ground if not supported.
- 4) Clean new bolts, lock-nuts, and washer with cleaner/degreaser. Prior to assembly, ensure all hardware is dry and free of any contaminants including the carrier assembly.
- 5) Use Primer Loctite on the bolts and nuts according to the directions on the label. Apply Loctite #243 to the first 10 bolt threads to ensure coverage.
- 6) Assemble the new blade, the bolt, and the nut to the carrier. The blade carrier cuts in one direction, counterclockwise.
- 7) Torque the blade bolts to 775 ft-lbs. using a 1-11/16" socket.
- 8) Confirm the blade carrier rotates freely and is clear of any obstructions.
- 9) Reinstall the access cover plate.

PARTS SECTION

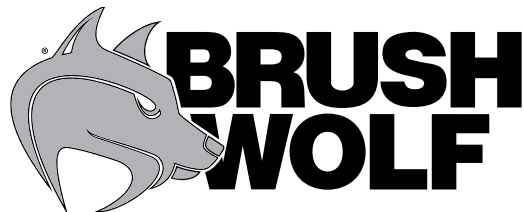

**ONLY USE GENUINE OEM PARTS
ORDER PARTS DIRECTLY
FROM BRUSH WOLF
BY CALLING 218-692-1050**

PARTS: 4201

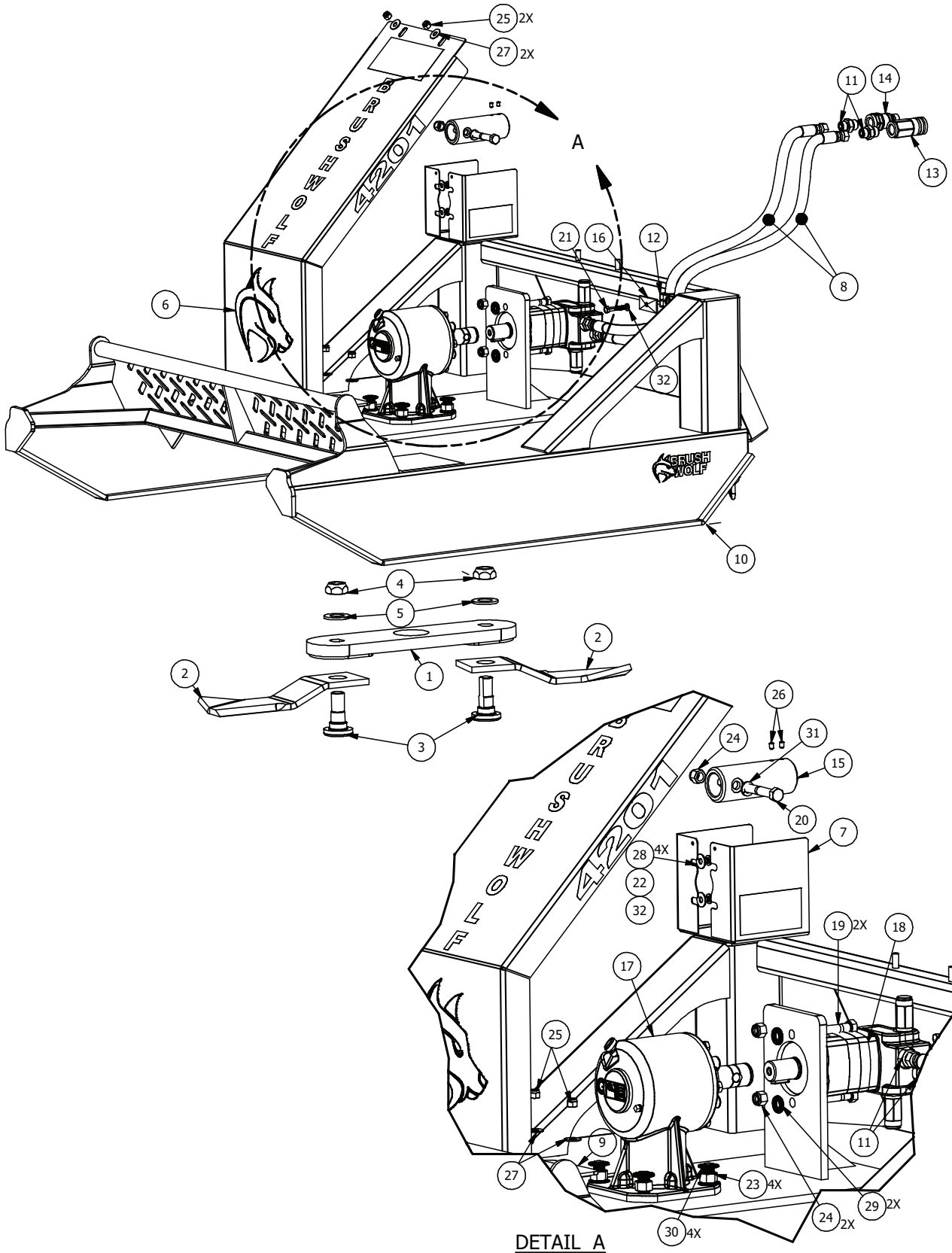

ONLY USE GENUINE OEM PARTS. ORDER PARTS FROM BRUSH WOLF AT **218-692-1050**

ITEM	ITEM QTY	PART NUMBER	DESCRIPTION
1	1	15096	WELDMENT, BLADE CARRIER, 20.000 X 5.000 X 1.000 PLATE
2	1	15265	SET OF BLADES, 14.750 X 4.000 X .500
3	2	15066	BOLT, D-BOLT, 1 1/8-12, BW
4	2	15148	NUT, TOP LOCK, 1 1/8-12, GRADE C, PLAIN
5	2	30089	WASHER, FLAT, 1 1/8, F436, ZINC
6	1	17038	DECAL KIT, 4201
7	1	15102	GUARD, COUPLING, BW, 4201
8	2	15631	HOSE WHIP ASSEMBLY, -8 ORFS, FEMALE SWIVEL COUPLINGS, 0.500 X 66.000 HOSE
9	1	15054	PLATE, ACCESS, 2 HOLE, 5.250 X 3.250 X 0.250
10	1	17032	WELDMENT, FRAME, 4201 DINGO
10	1	17033	WELDMENT, FRAME, 4201 MT-50
11	4	15584	ADAPTER, STRAIGHT, #8 MORFS, #10 MORB
12	1	15263	CLAMP, BODY, TWO PIECE, 22MM, TWO HOSE
13	1	15078	COUPLER, FLAT FACED, 1/2 FEMALE, 7/8-14, O-RING BOSS
14	1	15079	COUPLER, FLAT FACED, 1/2 MALE, 7/8-14, O-RING BOSS
15	1	15123	COUPLING, STD, 1.250 MOTOR, 1.375 GB, 5.500
16	1	15264	COVER PLATE, CLAMP, 22MM, TWO HOSE
17	1	15091	GEARBOX, 40 HP, 1.375 INPUT, 12 TOOTH SPLINE OUTPUT, 1:1.93 RATIO
18	1	15352	MOTOR, 4.9 CU IN, SAE "A" 2 BOLT, 7/8-14 SAE O-RING PORTS, 1.250 DIA X 1.250 KEYED SHAFT, 3500/750 RELIEF, EATON
19	2	30026	BOLT, HH, 1/2-13 X 2 UNC, GRD 5, ZINC
20	1	30029*	BOLT, HH, 1/2-13 X 3, GRD 2, ZINC
21	1	30052	BOLT, HH, 5/16-18 X 1 3/4, GRD 5, ZINC
22	4	30054	BOLT, HH, 5/16-18 X 3/4, GRD 5, ZINC
23	4	30071	NUT TOPLOCK 5/8-11 GRD8 ZINC
24	3	30062	NUT, NYLOCK, 1/2-13, ZINC
25	4	30065	NUT, NYLOCK, 3/8-16, ZINC
26	2	30078	SET SCREW_CP_1_4-20X3_8 UNC
27	4	30083	WASHER, FLAT, 3/8, ZINC
28	4	30082	WASHER, FLAT, 5/16, ZINC
29	2	15381	WASHER, NORD-LOCK, 0.500 X 1.000 OD, ZINC
30	4	15380	WASHER, NORD-LOCK, 0.625 X 1.210 OD, ZINC
31	1	30093	WASHER, SPRING LOCK, .500, ZINC
32	5	30091	WASHER, SPRING LOCK, 5/16, ZINC

* SHEAR BOLT

PARTS: 4801 LF | 4801 SF

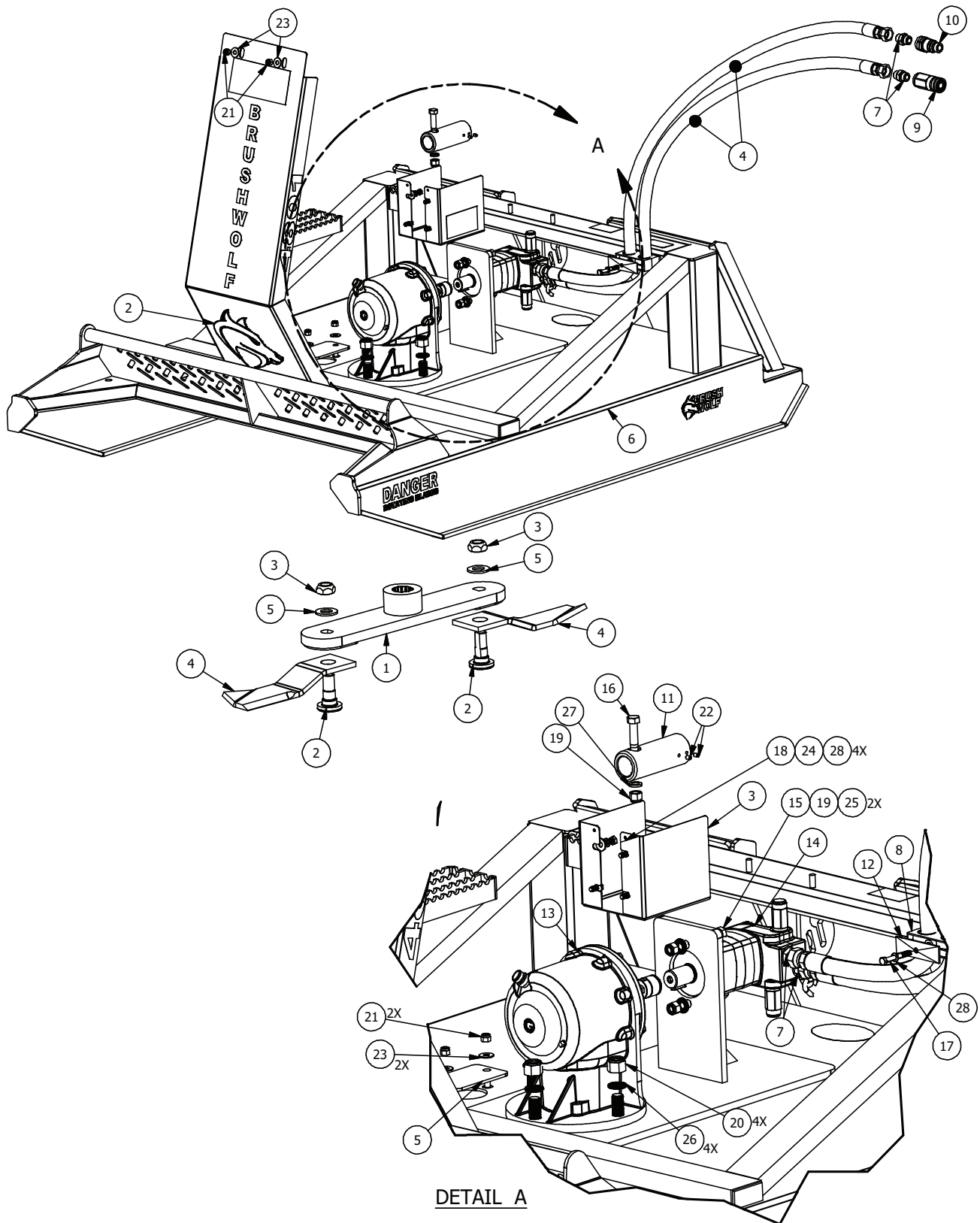

ONLY USE GENUINE OEM PARTS. ORDER PARTS FROM BRUSH WOLF AT **218-692-1050**

ITEM	ITEM QTY	PART NUMBER	DESCRIPTION
1	1	15098	WELDMENT, BLADE CARRIER, 26.000 X 5.000 X 1.000 PLATE
2	2	15066	BOLT, D-BOLT, 1 1/8-12, BW
3	2	15148	NUT, TOP LOCK, 1 1/8-12, GRADE C, PLAIN
4	1	15265	SET OF BLADES, 14.750 X 4.000 X .500
5	2	30089	WASHER, FLAT, 1 1/8, F436, ZINC
6	1	17039	DECAL KIT, 4801
7	1	15067	GUARD, COUPLING, BW, STD
8	2	15597	HOSE WHIP ASSEMBLY, -8 ORFS, FEMALE SWIVEL COUPLINGS, 0.750 X 78.000 HOSE
9	1	15054	PLATE, ACCESS, 2 HOLE, 5.250 X 3.250 X 0.250
10	1	17034**	WELDMENT, FRAME, 4801 STD
10	1	17035**	WELDMENT, FRAME, 4801 DINGO
10	1	17036**	WELDMENT, FRAME, 4801 MT-50
10	1	17037**	WELDMENT, FRAME, 4801 ASV
11	4	15584	ADAPTER, STRAIGHT, #8 MORFS, #10 MORB
12	1	15248	CLAMP, BODY, TWO PIECE, 30MM, TWO HOSE
13	1	15078	COUPLER, FLAT FACED, 1/2 FEMALE, 7/8-14, O-RING BOSS
14	1	15079	COUPLER, FLAT FACED, 1/2 MALE, 7/8-14, O-RING BOSS
15	1	15123	COUPLING, STD, 1.250 MOTOR, 1.375 GB, 5.500
16	1	15249	COVER PLATE, CLAMP, 30MM, TWO HOSE
17	1	15093	GEAR BOX, 62HP, 1:1.93 RATIO
18	1	15353**	STANDRARD FLOW BRUSH CUTTER - MOTOR, 6.2 CU IN, SAE "A" 2 BOLT, 7/8-14-12 SAE O-RING PORTS, 1.250 DIA X 1.250 KEYED SHAFT, 3500/750 RELIEF, EATON
18	1	15352**	LOW FLOW BRUSH CUTTER - MOTOR, 4.9 CU IN, SAE "A" 2 BOLT, 7/8-14 SAE O-RING PORTS, 1.250 DIA X 1.250 KEYED SHAFT, 3500/750 RELIEF, EATON
19	2	30026	BOLT, HH, 1/2-13 X 2 UNC, GRD 5, ZINC
20	1	30029*	BOLT, HH, 1/2-13 X 3, GRD 2, ZINC
21	1	30053	BOLT, HH, 5/16-18 X 2 1/2, GRD 5, ZINC
22	4	30054	BOLT, HH, 5/16-18 X 3/4, GRD 5, ZINC
23	3	30062	NUT, NYLOCK, 1/2-13, ZINC
24	4	30064	NUT, NYLOCK, 3/4-10, ZINC
25	4	30065	NUT, NYLOCK, 3/8-16, ZINC
26	2	30078	SET SCREW_CP_1_4-20X3_8 UNC
27	4	30083	WASHER, FLAT, 3/8, ZINC
28	4	30082	WASHER, FLAT, 5/16, ZINC
29	2	15381	WASHER, NORD-LOCK, 0.500 X 1.000 OD, ZINC
30	4	15379	WASHER, NORD-LOCK, 0.750 X 1.210 OD, ZINC
31	1	30093	WASHER, SPRING LOCK, .500, ZINC
32	5	30091	WASHER, SPRING LOCK, 5/16, ZINC

* SHEAR BOLT

** DEPENDS ON THE MODEL OF BRUSH CUTTER

WARRANTY INFORMATION

PROTECT YOUR PURCHASE.

Warranties are valid from date of purchase with a warranty registration on file. Scan the QR code below or go to brushwolf.com/warranty to file a claim and view warranty details.

5 YEAR
LIMITED
WARRANTY

Structural Components • Materials • Weldment

2-YEAR
LIMITED WARRANTY



Hydraulic Motor

1.5-YEAR
LIMITED WARRANTY



Gearbox



Bearing Housing

