

Operator's Manual

SKID STEER BRUSH CUTTERS

ALPHA Series

ALPHA HD | ALPHA XP

WHY READ THIS MANUAL?

Before operating your new Brush Wolf brush cutter, read this entire manual to understand **1) safety precautions, 2) operating instructions, and 3) maintenance schedule** to help keep you safe and your equipment running smoothly for years to come.



TAKE A MINUTE TO WRITE DOWN THE FOLLOWING INFORMATION
FOR FUTURE SERVICE, REPAIR, AND WARRANTY INQUIRIES.

OWNER REFERENCE INFORMATION

DATE OF PURCHASE _____

MODEL NO. _____

SERIAL NO. _____

DEALER NAME _____

SALES REP NAME _____

DEALER PHONE NO. _____

DEALER EMAIL _____

DEALER ADDRESS _____

THANK YOU

Welcome to the Brush Wolf family!

You've made a smart choice! We hope you love your brush cutter as much as we love making it. If you have any issues, please contact us at any time. We're here to help.

Brush Wolf

218-692-1050

info@brushwolf.com

brushwolf.com

WHAT'S INSIDE

SAFETY FIRST!	2-3
OPERATING YOUR BRUSH CUTTER	4-6
MAINTENANCE	7-9
TROUBLESHOOTING	10
PARTS SECTION	
ALPHA PARTS	12-13
BLADE CARRIER: (3) DROP-BLADES	
PARTS	14
HOW TO REPLACE	15
BLADE CARRIER: (4) FLAT-BLADES	
PARTS	16
HOW TO REPLACE	17
WARRANTY INFORMATION	18

SAFETY FIRST!

FOR YOUR SAFETY, READ THESE INSTRUCTIONS.

The following safety instructions are provided to alert you to precautions that, if not followed, may cause serious injury to yourself or to others. Please read these instructions completely. Brush Wolf/Cross-Tech Manufacturing cannot cover every incident that might be a hazard. Extreme caution should be used at all times. Only use your Brush Wolf brush cutter for the purpose for which it has been designed.

SITE INSPECTION

Before operating your brush cutter, carefully inspect the area to be cleared. Remove any items that may be picked up and thrown by the cutting blades, such as wire, pipes, rocks, etc. Mark objects that are too large to move. This is an important step to avoid personal injury, damage to property, the brush cutter, or your skid steer. If an object is struck while operating the brush cutter, immediately shut down power to both the brush cutter and the skid steer. Any damage should be corrected and tested before the continuation of cutting.

SKID STEER AUXILIARY HYDRAULIC FLOW

Check the specifications of your brush cutter's rated gallons per minute (GPM) to correctly match the hydraulic flow of your skid steer to ensure proper operation.

EQUIPMENT INSPECTION

Disconnect the unit from the skid steer. To inspect or to make repairs under the cutter deck, always block the unit securely to prevent accidental release of the lift mechanism.

Inspect all hydraulic connections to ensure they are tight, and hoses and shields are in good condition before applying pressure. Hydraulic fluid can escape under pressure and may cause serious injury or death. If this type of injury occurs, seek medical attention immediately.

SAFETY GEAR

Wear safety goggles, hearing protection, and a hard hat. Only operate the skid steer behind a shatterproof forestry-rated door and cab.

DO NOT operate within 300' of bystanders, vehicles, pets, livestock, or buildings. Objects may discharge while cutting with the brush cutter and has the potential to cause serious injury.

DO NOT operate the brush cutter until everyone on your work crew is alerted to the dangers of walking up to the brush cutter while in operation.

DO NOT operate the brush cutter in conditions with poor visibility.

DO NOT operate while intoxicated or if taking medications that may impair your senses or reactions.

DO NOT allow children to operate the brush cutter. Only individuals with skid steer experience who are well acquainted with the rules of safe operation should be allowed to operate the brush cutter.

DO NOT operate the skid steer without a shatterproof forestry-rated door and cab.

DO NOT place hands, feet, or other objects under the deck while the brush cutter is in operation.

DO NOT raise the mower deck while blades are rotating. Operation with the mower raised will expose the cutting blades and may cause serious injury or death to yourself or others.

DO NOT allow anyone or any item on top of the mower deck while in operation.

DO NOT expose the underside of the blades towards the cab while in operation.

DO NOT continue operation if an unexpected object is struck. IMMEDIATELY shut down power to both the brush cutter and the skid steer. Disconnect the hydraulic couplers from the power source. Evaluate the damage, repair, and then test the unit before operation.

DO NOT leave the brush cutter unattended while in a raised position. Always make sure both the runners are placed firmly on the ground and shut down the skid steer.

DO NOT attempt to straighten blades. Order replacement blades if blades are bent, cracked, or damaged.

OPERATING YOUR BRUSH CUTTER

▶ START HERE

Verify your skid steer's hydraulic flow to ensure it is within the brush cutter's rating range. The brush cutter's gallons per minute (GPM) rating is located on the serial tag of the brush cutter.

ALPHA HD 23-32 GPM

ALPHA XP 33-45 GPM

The maximum operating pressure is 4,000 psi.

FIGURE 1: SERIAL TAG

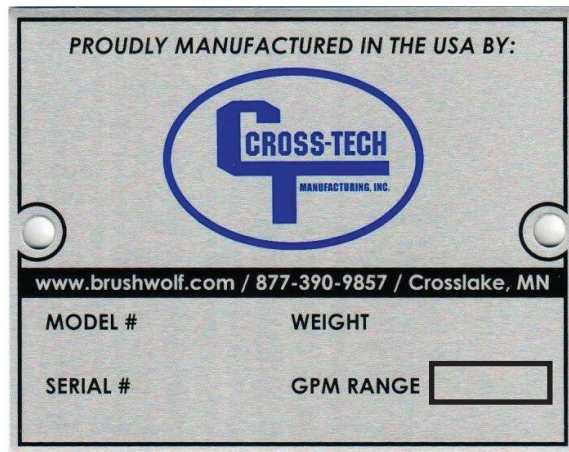

▶ IMPORTANT: CHECK THESE ITEMS PRIOR TO OPERATING

CHECK BLADES

Inspect blades to ensure they are sharp, tightened correctly, and intact. Look for damage, dullness, and cracks. See page 8 for details.

CHECK NUTS & BOLTS

Check all nuts and bolts for proper tightness. See maintenance schedule for torque specification listed on page 9.

CHECK HYDRAULIC FLUID

A low level could indicate a leak and require a closer inspection of your unit. See page 8 for details.

INSPECT THE DRIVE COMPONENTS

Remove any foreign material.

► CONNECTING THE BRUSH CUTTER

- 1) Connect the brush cutter to your skid steer with the universal Quick Tach Mount Plate.
- 2) Once connected, visually check the lock pins to make sure the brush cutter is securely locked into place.

NOTE: All Brush Wolf brush cutters come from the factory with the female flat faced coupler on the pressure line and the male coupler on the return line.

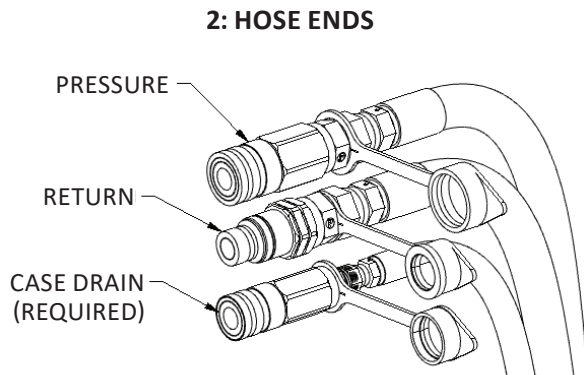

- 3) Inspect the hydraulic couplers and wipe off water, dust, or any debris which can damage hydraulic components. Once cleaned, connect the couplers from the cutter to the auxiliary hydraulic system on the skid steer. Twist the collars of the quick connect couplers to secure the hydraulic connections. **ALL OPEN FRONT/ EXTREME-DUTY BRUSH CUTTERS REQUIRE A CASE DRAIN LINE.** Failure to run without a case drain line or an improperly connected case drain line will result in excess case pressure. All motors are equipped with a check valve on the top of the motor to relieve excess case pressure. Should you see leaking from the check valve, make sure the case drain line is connected properly. Operating the brush cutter without a case drain line will cause damage to the motor and void the warranty.
- 4) Make sure the hoses are routed in a way that allows the head to make a full range of motion. If hoses are too long and pinching or binding, they can be made shorter by loosening the hose bracket and feeding additional hose length back to the cutter deck.
- 5) Confirm all safety measures have been completed per the Safety First! section (pages 2-3). Most importantly, make sure the area is clear of people and pets.

▶ OPERATING STEPS

- 1) Enter the shatter-proof cab door, engage the seat belt, release the brake, and start the engine. The runners of the brush cutter should be as close to the ground as possible. **Never raise the brush cutter more than seven (7) inches off the ground while in operation.**
- 2) Slowly apply hydraulics to the brush cutter and increase the engine speed to high idle. Make sure the unit is operating smoothly before moving the skid steer forward.
- 3) Check for proper blade rotation. **Blades should spin COUNTERCLOCKWISE as viewed from above** (see Figure 3). If rotation is reversed (clockwise), either inverse the flow from your machine or switch the QD couplers on the hose ends.

When temperatures are below zero, allow additional time for hydraulic fluid to warm up.

- 4) **Maintain skid steer speed** appropriate for the volume of brush to prevent stalling.
- 5) Stay alert for drop-offs, rocks, holes, abandoned wells, and septic tanks. Do not operate or drive across a steep embankment as this may cause a rollover and possible injuries or death.
- 6) To **cut large diameter brush and trees**, move forward slowly to make the cut.

FIGURE 3: BLADE ROTATION

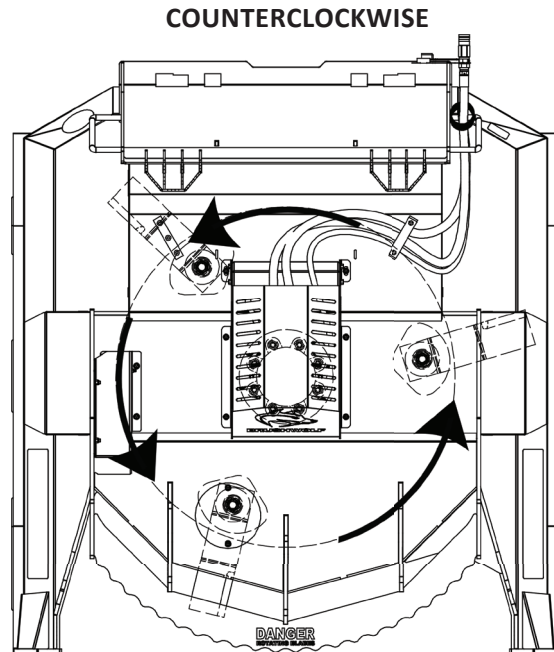

▶ WHEN DONE CUTTING

When done, lower lift arms, make sure the cutter is placed flat on the ground, throttle down on the skid steer, and shut off the hydraulic flow to the brush cutter. Stop the engine and engage the parking brake before leaving the cab.

DISCONNECTING HOSES:

To disconnect hoses, use proper hand protection as the couplers may be hot. Always replace caps on hoses once removed to prevent contamination.

MAINTENANCE

BRUSH WOLF BRUSH CUTTERS ARE BUILT TO STRICT STANDARDS AND WILL DELIVER YEARS OF DEPENDABLE SERVICE WHEN YOU FOLLOW THESE MAINTENANCE GUIDELINES...

► MAINTENANCE SCHEDULE

See pages 8-9 for details.

ITEM	BEFORE EACH USE	DAILY OR EVERY 8 HOURS	AS NEEDED
Blades	Inspect		
Bearing Housing Lubricant	Check Oil		
Blade Bolt/Nuts		(3) Drop-Blade Carrier: torque to 775 ft-lbs (4) Flat-Blade Carrier: torque 275 ft-lbs	
Bearing Housing Nuts		Torque to 230 ft-lbs	
Blade Carrier to Bearing Housing Bolts		Torque to 380 ft-lbs	
Hydraulic Motor Mount Bolts		Torque to 75 ft-lbs	
Block Bolts		Torque to 100 ft-lbs	
Spacers: (4) Flat-Blade Carrier Only		Torque to 275 ft-lbs	
Bearing Housing	Inspect		
Hoses & Hose Safety Shield	Inspect		
Brush Cutter			Clean

CAUTION: Perform maintenance on a level surface with the unit firmly on the ground and blocked. Shut down the skid steer and remove hydraulic hoses from the power source.

DO NOT loan your brush cutter to another skid steer owner. The potential exists for hydraulic contamination and could shorten the life of your skid steer or the hydraulic motor on your brush cutter. Contamination of the hydraulic motor voids the warranty.

▶ BEFORE EVERY OPERATION

☐ INSPECT BLADES

Inspect blades before each use to ensure they are sharp, tightened correctly, and intact. Look for damage, dullness, and cracks. Blades should rotate freely and be clear of obstructions. Replace the entire set of blades if damaged.

CAUTION: Always replace the entire set of blades. Never weld or straighten damaged blades, as loss of blade integrity may result.

☐ INSPECT THE DRIVE COMPONENTS

Inspect before each use and remove foreign material.

☐ CHECK THE BEARING HOUSING FOR PROPER LUBRICANT

To check the lubricant level, remove the pipe plug from the side of the bearing housing. See Figure 4 for oil level and quantity. If low, add 80W90 gear lube.

☐ CHECK HYDRAULIC HOSES AND HOSE SAFETY SHIELD

Check for wear, damage, or leaks. Replace if damaged.

FIGURE 4: OIL PORT

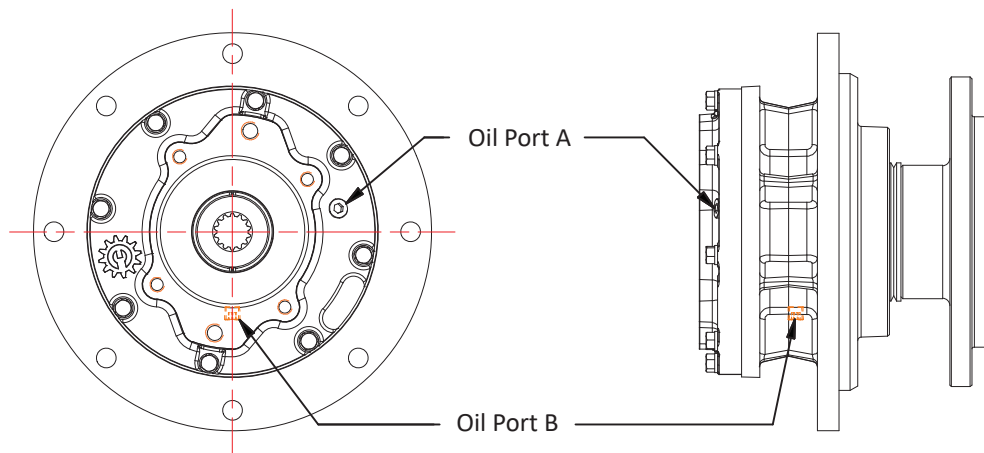

Oil Capacities

Mounting Position	
Vertical Spindle Down	17 oz/.50 L Fill to Oil Port A while held in horizontal position as shown

► BEFORE EVERY OPERATION

CHECK NUTS & BOLTS

Every Brush Wolf brush cutter is tested at the factory and all nuts and bolts have been tightened to specifications. We recommend you check the nuts and bolts after the first 4 to 6 hours of operation; then daily or every eight (8) hours.

Tighten the nuts that secure the blades to the blade carrier every eight (8) hours.

For the (3) Drop-Blade Carrier: torque the nuts to 775 ft-lbs with a 1-11/16" socket wrench.

For the (4) Flat-Blade Carrier: torque to 275 ft-lbs with a 1-1/8" socket wrench. AND Torque the puck bolts to 100 ft-lbs.

The nuts are located under the access plate on the top of the blade carrier (see Figure 5).

Also, tighten the nuts holding the blade carrier to the output shaft of the bearing housing, torque to 380 ft-lbs with a 15/16" socket wrench.

Tighten bearing housing mounting bolts daily or every eight (8) hours. Torque the bolts to 230 ft-lbs.

Tighten hydraulic motor mount bolts daily or every eight (8) hours. Torque the bolts to 75 ft-lbs.

Torque the block bolts to 100 ft-lbs.

FIGURE 5: ACCESS COVER

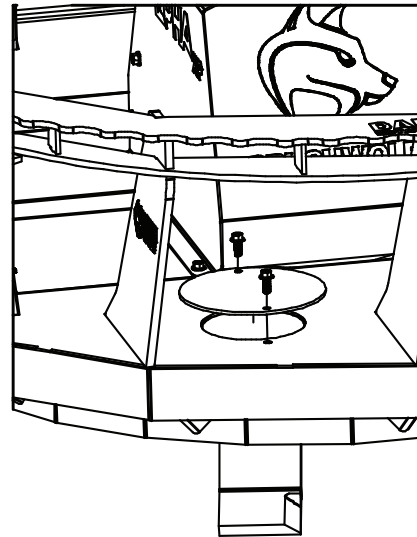

► AS NEEDED

- CLEAN THE BRUSH CUTTER** as needed and look for potential damage or obstruction that could result in poor performance.
- Make sure all **SAFETY DECALS** are visible.

TROUBLESHOOTING

CONSULT YOUR DEALER OR CONTACT BRUSH WOLF FOR ANY QUESTIONS OR ADDITIONAL HELP.

ISSUE	POTENTIAL CAUSES
Loss of Power	<ul style="list-style-type: none">• Low hydraulic fluid level• Overheated hydraulic fluid*• Contaminated hydraulic fluid*• Low gearbox lubricant level
Excessive Unit Vibration	<ul style="list-style-type: none">• Dull, broken, or damaged blades• Blade carrier out of balance• Loose nuts and bolts• New blade or bolts matched with worn blade or bolts• Wire or rope wrapped around blades
Leaking Oil	<ul style="list-style-type: none">• Loose hydraulic connections• Ruptured hydraulic motor seals**• Loose or missing motor drain plug• Leaking from motor safety valve: check case drain line for proper connection• Leaking from bearing housing safety valve: blown motor seal

*May damage hydraulic motor and void warranty.

**The bearing housing is equipped with a 5 psi check valve on the fill plug to save the bearing housing seal should the motor seals become compromised. Some amount of oil seepage may be possible if cutter is run at extreme vertical angles. Excessive leakage from the check valve is indicative of a blown motor seal. Brush cutter should be shut down immediately to keep from compromising the bearing housing seal.

PARTS SECTION

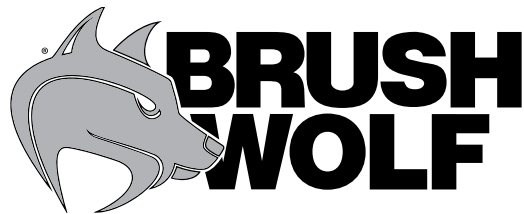

**ONLY USE GENUINE OEM PARTS
ORDER PARTS DIRECTLY
FROM BRUSH WOLF
BY CALLING 218-692-1050**

PARTS: ALPHA HD | ALPHA XP

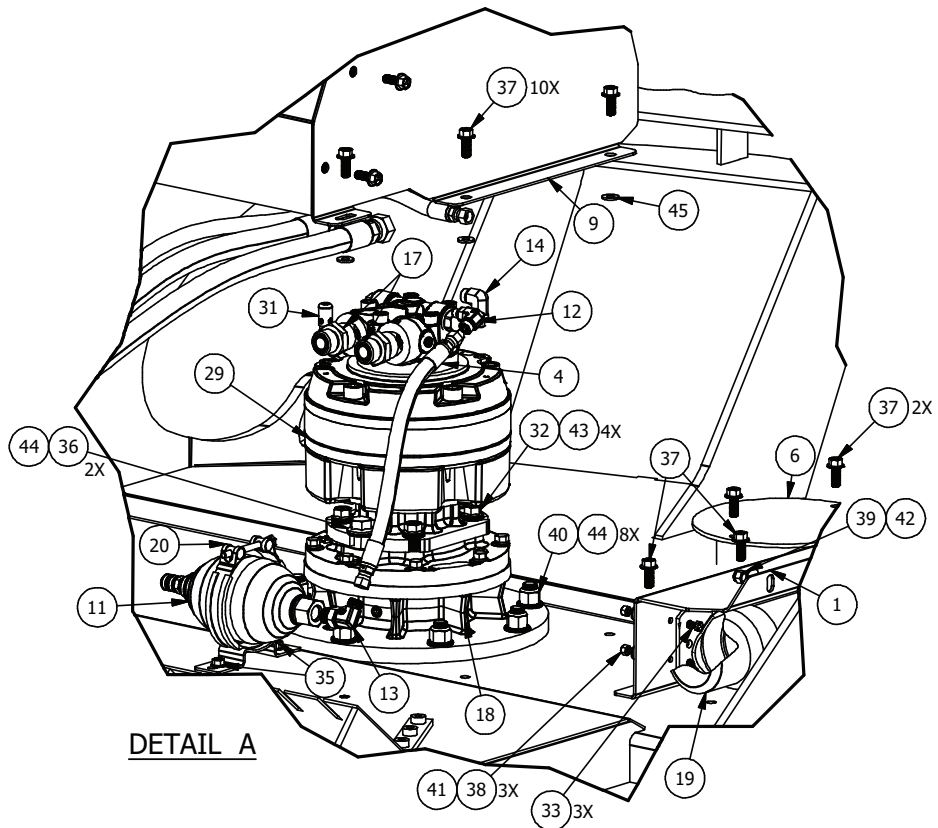
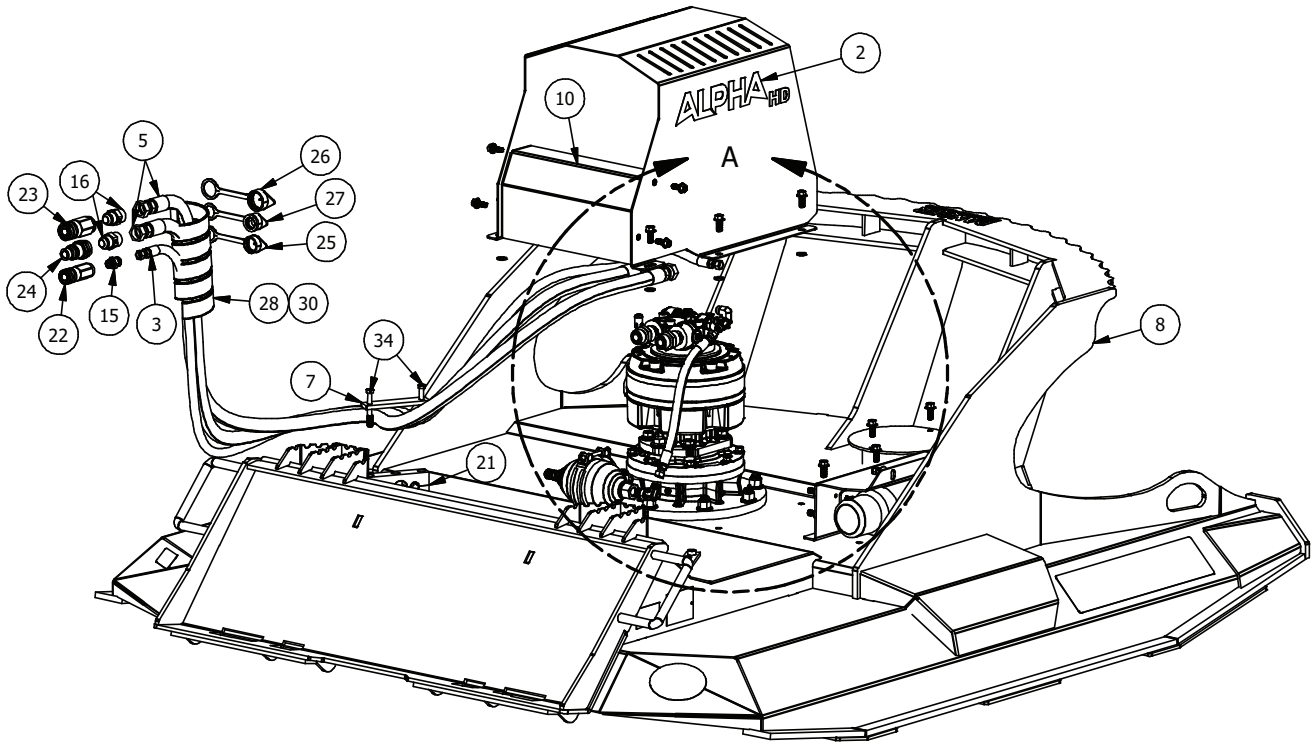

ITEM	ITEM QTY	PART NUMBER	DESCRIPTION
1	1	15389	COVER, OMM,CORNER MOUNT, INTL STYLE
2	1	16572	ALPHA HD - DECAL KIT, ALPHA HD
2	1	16527	ALPHA XP - DECAL KIT, ALPHA XP
3	1	16525	HOSE WHIP ASSEMBLY, -6 ORFS, FEMALE SWIVEL COUPLINGS, 0.375 X 130.000 HOSE
4	1	16871	HOSE WHIP ASSEMBLY, -6 ORFS, FEMALE SWIVEL COUPLINGS, 0.375 X 12.000 HOSE
5	2	15587	HOSE WHIP ASSEMBLY, -12 ORFS, FEMALE SWIVEL COUPLINGS, 0.750 X 114.000 HOSE
6	1	16271	PLATE, ACCESS, 2 HOLE, 9.000 DIA
7	1	15418	PLATE, STAUFF, 3 HOLE COVER, 1.25 X 5.875
8	1	16253	WELDMENT, FRAME, ALPHA
9	1	16865	WELDMENT, HOOD, BOLT ON, ALPHA
10	1	16890	WELDMENT, COVER INSERT, ALPHA
11	1	16861	ACCUMULATOR, BLADDER, 0.7L
12	1	16864	ADAPTER, 90 DEG, #6 MORFS, #4 MORB
13	1	16237	ADAPTER, 90 DEG, #8 MORB, #6 MORFS
14	1	16501	ADAPTER, 90 DEG, 1/4MBSPP, #6 MOFS
15	1	15408	ADAPTER, STRAIGHT, #6 MORFS, #8 MORB
16	2	15405	ADAPTER, STRAIGHT, #12 MORF, #12 MORB
17	2	15689	ADAPTER, STRAIGHT, #12 MORFS MALE, #16 MORB
18	1	16423	BEARING HOUSING, SAE "C" MOUNT, 3.250 SHAFT, 10.750 SPINDLE OUTPUT
19	1	15417	CANISTER, OMM, INTERNATIONAL STYLE, 12.500 X 3.500
20	1	16862	CLAMP, BLADDER ACCUMULATOR, 0.7L
21	1	15401	CLAMP, BODY, TWO PIECE, 30-30-18, THREE HOSE, BLACK
22	1	15414	COUPLER, FLAT FACED, 3/8 FEMALE, 3/4-16, O-RING BOSS
23	1	15114	COUPLER, FLAT FACED, 5/8 FEMALE, 1 1/6-12, O-RING BOSS
24	1	15115	COUPLER,FLAT FACED, 5/8 MALE, 1 1/6-12, O-RING BOSS
25	1	16562	DUST CAP, 0.375 COUPLER, FEMALE
26	1	16565	DUST CAP, 0.625 COUPLER, FEMALE
27	1	16566	DUST CAP, 0.625 COUPLER, MALE
28	48"	16526	HOSE WRAP, SPIRAL, 3.000
28	1	16764	ALPHA HD - MOTOR, 150CC, A3 SAE C MOUNT, WITH CROSSPORT RELIEF
29	1	16763	ALPHA XP - MOTOR, 175CC, A3 SAE C MOUNT, WITH CROSSPORT RELIEF
30	2	16559	ZIP TIE, 15 INCH, 120LB. BREAK STRENGTH, BLK
31	1	16893	VALVE, SAFETY, 1/4 BSPP, 16 BAR
32	4	30123	BOLT, HH, FLANGED, 1/2-13 X 1 1/2, GRD 5, ZINC
33	3	30032	BOLT, HH, 1/4-20 X 1 UNC, GRD 5, ZINC
34	2	30044	BOLT, HH, 3/8-16 X 3, GRD 5, ZINC
35	2	30119	BOLT, HH, FLANGED, 5/16-24 X 3/4, GRD 5, ZINC
36	2	30122	BOLT, HH, FLANGED, 5/8-11 X 1 1/2, GRD 8, ZINC
37	10	30058	BOLT, HH, FLANGED, SERRATED, 3/8-16 X 1, GRD 5, ZINC
38	3	30063	NUT, NYLOCK, 1/4-20, ZINC
39	2	30065	NUT, NYLOCK, 3/8-16, ZINC
40	8	30067	NUT, NYLOCK, 5/8-18,GRD 8 ZINC
41	3	30081	WASHER, FLAT, 1/4, ZINC
42	2	30083	WASHER, FLAT, 3/8, ZINC
43	4	15381	WASHER, NORD-LOCK, 0.500 X 1.000 OD, ZINC
44	10	15380	WASHER, NORD-LOCK, 0.625 X 1.210 OD, ZINC
45	6	15685	WASHER, RUBBER SEAL, 0.812 OD X 0.355 ID X .094

PARTS: (3) DROP BLADE CARRIER

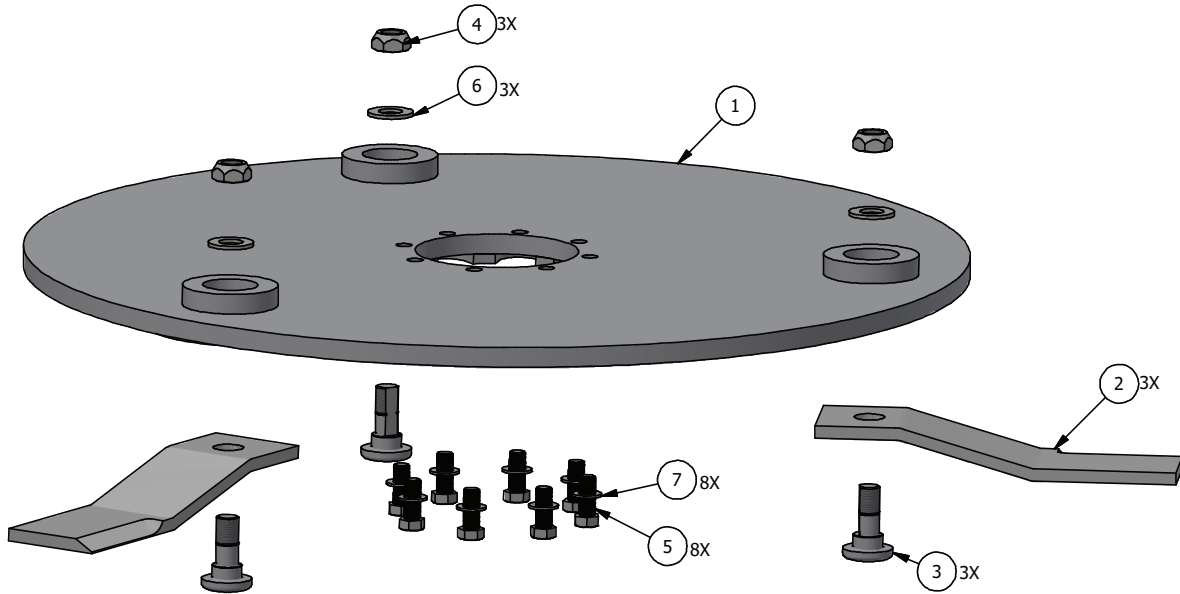

15203 DROP BLADE CARRIER ASSEMBLY

ITEM	ITEM QTY	PART NUMBER	DESCRIPTION
1	1	15095	WELDMENT, BLADE CARRIER, 47.000 DIA X 1.000 PLATE, M-AX
2	1	15272	SET OF BLADES, 18.000 X 5.000 X 0.625
3	3	15101	BOLT, D-BOLT, 1 1/8-12, M-AX
4	3	15148	NUT, TOP LOCK, 1 1/8-12, GRADE C, PLAIN
5	8	30112	BOLT_HH_3_4-16X2 UNC_GRD8 YZ
6	3	30089	WASHER, FLAT, 1 1/8, F436, ZINC
7	8	30087	WASHER, FLAT, 3/4, F436, ZINC

ONLY USE GENUINE OEM PARTS. ORDER PARTS FROM BRUSH WOLF AT **218-692-1050**

► HOW TO REPLACE (3) DROP BLADES

Perform replacement on a level surface with the brush cutter blocked off the ground. Shut off the hydraulic power supply and disconnect hydraulic couplers.

- 1) Take off the access cover (see Figure 5 on page 9) by removing the nuts and washers.
- 2) Through the exposed access hole, rotate the blade carrier to line up the nut of the blade for access.
- 3) Insert a 1-11/16" socket through the access hole and remove the nut and drop the bolts. **Caution:** once nuts are removed, blades will fall to the ground if not supported.
- 4) Clean new bolts, lock-nuts, and washer with cleaner/degreaser. Prior to assembly, ensure all hardware is dry and free of any contaminants including the carrier assembly.
- 5) Use Primer Loctite on the bolts and nuts according to the directions on the label. Apply Loctite #243 to the first 10 bolt threads to ensure coverage.
- 6) Assemble the new blade, the bolt, and the nut to the carrier. The blade carrier cuts in one direction, counterclockwise.
- 7) Torque the blade bolts to 775 ft-lbs. using a 1-11/16" socket.
- 8) Confirm the blade carrier rotates freely and is clear of any obstructions.
- 9) Reinstall the access cover plate.

PARTS: (4) FLAT BLADE CARRIER

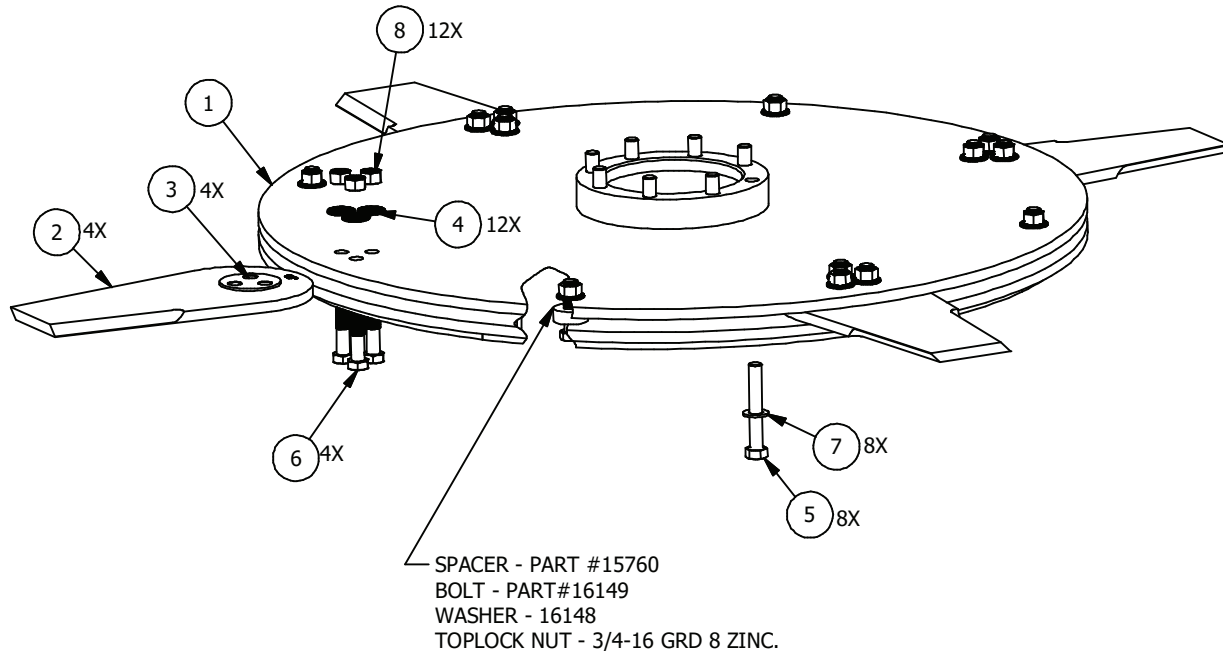

AVAILABLE AS SERVICE PARTS.

15202 FLAT BLADE CARRIER ASSEMBLY

ITEM	ITEM QTY	PART NUMBER	DESCRIPTION
1	1	16200	ASSEMBLY, BLADE CARRIER, M-AX, FLAT DISCS
2	1	15273	SET OF BLADES, FLAT, 18.000 X 8.500 X 0.625
3	4	15099	PUCK, 3.500 DIA X 0.750, 3 HOLE
4	12	16148	WASHER, NORD-LOCK, 0.750 X 1.540 OD, ZINC
5	8	30037	BOLT, HH, 3/4-10 X 5, GRD 8, ZINC
6	12	16149	BOLT 3/4-16x3 GR 8 LONG SHOULDER
7	8	30087	WASHER, FLAT, 3/4, F436, ZINC
8	12	30070	NUT TOPLOCK 3/4-16 GRD8 ZINC

ONLY USE GENUINE OEM PARTS. ORDER PARTS FROM BRUSH WOLF AT **218-692-1050**

► HOW TO REPLACE (4) FLAT BLADES

Brush Wolf's flat blades are reversible. Just turn over all blade at the same time. When replacing blades, an entire new set of four (4) blades, pucks, bolts and washers must be replaced at the same time. Follow the instructions below. Perform replacement on a level surface with the brush cutter blocked off the ground. Shut off the hydraulic power supply and disconnect hydraulic couplers.

- 1) Take off the access cover (see Figure 5 on page 9) by removing the nuts and washers.
- 2) Through the exposed access hole, rotate the blade carrier to line up the nut of the blade for access.
- 3) Insert a 1-1/8" socket through the access hole and remove three (3) nuts for each blade.
- 4) Pound out the bolt using a drift pin or center punch to prevent damaging the threads.
- 5) Slide puck and blade out.
- 6) Clean blades, pucks, bolts, lock-nuts, and washer with cleaner/degreaser. Prior to assembly, ensure all hardware is dry and free of any contaminants including the carrier assembly.
- 7) Insert the new puck and blade between carrier assembly. Line up with the bolt holes. **Note:** All four blades must be turned over at the same time. If the reverse side of the blades have not been used, turn the blade over. The blade carrier cuts in one direction, counterclockwise. Worn or damaged pucks, bolts, and washers must be replaced in sets.
- 8) Apply Loctite #243 to the first ten bolt threads to ensure coverage.
- 9) Assemble the bolt, washer, and nut to the carrier as shown in the diagram on page 16.
- 10) Torque the blade bolts to 275 ft-lbs.
- 11) Confirm the blade carrier rotates freely and is clear of any obstructions.
- 12) Reinstall the access cover plate.

WARRANTY INFORMATION

PROTECT YOUR PURCHASE.

Warranties are valid from date of purchase with a warranty registration on file. Scan the QR code below or go to brushwolf.com/warranty to file a claim and view warranty details.

5 YEAR
LIMITED
WARRANTY

Structural Components • Materials • Weldment

2-YEAR
LIMITED WARRANTY



Hydraulic Motor

1.5-YEAR
LIMITED WARRANTY



Gearbox



Bearing Housing

